



SEMITOP[®] 2

IGBT Module

SK50GARL065F

Preliminary Data

Features

- Compact design
- One screw mounting
- Heat transfer and isolation through direct copper bonded aluminium oxide ceramic (DCB)
- N-channel homogeneous silicon structure (NPT-Non punch-through IGBT)
- Low tail current with low temperature dependence
- Low threshold voltage
- Fast Turbo diode

Typical Applications*

- Switching (not for linear use)
- Inverter
- Switched mode power supplies
- UPS

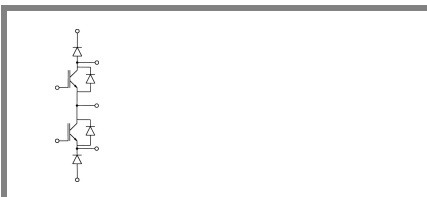

GARL

Absolute Maximum Ratings		$T_s = 25\text{ °C}$, unless otherwise specified		
Symbol	Conditions	Values		Units
IGBT				
V_{CES}	$T_j = 25\text{ °C}$	600		V
I_C	$T_j = 125\text{ °C}$	$T_s = 25\text{ °C}$	54	A
		$T_s = 80\text{ °C}$	40	A
I_{CRM}	$I_{CRM} = 2 \times I_{Cnom}$	120		A
V_{GES}		± 20		V
t_{psc}	$V_{CC} = 300\text{ V}; V_{GE} \leq 20\text{ V}; T_j = 125\text{ °C}$ $V_{CES} < 600\text{ V}$	10		μs
Inverse Diode				
I_F	$T_j = 150\text{ °C}$	$T_s = 25\text{ °C}$	25	A
		$T_s = 80\text{ °C}$	17	A
I_{FRM}	$I_{FRM} = 2 \times I_{Fnom}$			A
I_{FSM}	$t_p = 10\text{ ms}; \text{half sine wave } T_j = 150\text{ °C}$	100		A
Freewheeling Diode				
I_F	$T_j = 150\text{ °C}$	$T_{case} = 25\text{ °C}$	82	A
		$T_{case} = 80\text{ °C}$	50	A
I_{FRM}	$I_{FRM} = 2 \times I_{Fnom}$	120		A
Module				
$I_{t(RMS)}$				A
T_{vj}		-40 ... +150		$^{\circ}\text{C}$
T_{stg}		-40 ... +125		$^{\circ}\text{C}$
V_{isol}	AC, 1 min.	2500		V

Characteristics		$T_s = 25\text{ °C}$, unless otherwise specified				
Symbol	Conditions	min.	typ.	max.	Units	
IGBT						
$V_{GE(th)}$	$V_{GE} = V_{CE}, I_C = 0,7\text{ mA}$	3	4	5	V	
I_{CES}	$V_{GE} = 600\text{ V}, V_{CE} = V_{CES}, T_j = 25\text{ °C}$			0,0022	mA	
I_{GES}	$V_{CE} = 0\text{ V}, V_{GE} = 20\text{ V}, T_j = 25\text{ °C}$			120	nA	
V_{CE0}		$T_j = 25\text{ °C}$	1,2	1,3	V	
		$T_j = 125\text{ °C}$	1,1	1,2	V	
r_{CE}	$V_{GE} = 15\text{ V}$	$T_j = 25\text{ °C}$			12	$\text{m}\Omega$
		$T_j = 125\text{ °C}$			22	$\text{m}\Omega$
$V_{CE(sat)}$	$I_{Cnom} = 60\text{ A}, V_{GE} = 15\text{ V}$	$T_j = 25\text{ °C}_{chiplev.}$	1,7	2	V	
		$T_j = 125\text{ °C}_{chiplev.}$	2,2	2,2	V	
C_{ies}	$V_{CE} = 25, V_{GE} = 0\text{ V}$	$f = 1\text{ MHz}$			3,2	nF
C_{oes}					0,3	nF
C_{res}					0,18	nF
Q_G	$V_{GE} = 0 \dots 20\text{ V}$			368	nC	
$t_{d(on)}$	$R_{Gon} = 15\ \Omega$	$V_{CC} = 300\text{ V}$ $I_C = 40\text{ A}$			47	ns
t_r					40	ns
E_{on}	$R_{Goff} = 15\ \Omega$	$T_j = 125\text{ °C}$ $V_{GE} = \pm 15\text{ V}$			1,03	mJ
$t_{d(off)}$					203	ns
t_f					33	ns
E_{off}					0,8	mJ
$R_{th(j-s)}$	per IGBT			0,85	K/W	

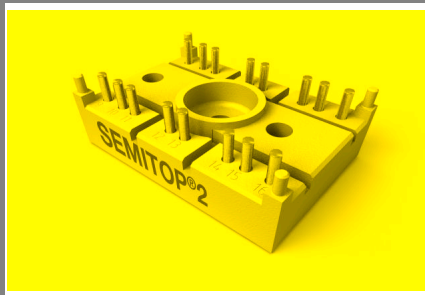

SEMITOP[®] 2

IGBT Module

SK50GARL065F

Preliminary Data

Features

- Compact design
- One screw mounting
- Heat transfer and isolation through direct copper bonded aluminium oxide ceramic (DCB)
- N-channel homogeneous silicon structure (NPT-Non punch-through IGBT)
- Low tail current with low temperature dependence
- Low threshold voltage
- Fast Turbo diode

Typical Applications*

- Switching (not for linear use)
- Inverter
- Switched mode power supplies
- UPS



GARL

Characteristics				min.	typ.	max.	Units
Symbol	Conditions						
Inverse Diode							
$V_F = V_{EC}$	$I_{Fnom} = 15 \text{ A}; V_{GE} = 0 \text{ V}$	$T_j = 25 \text{ }^\circ\text{C}_{\text{chiplev.}}$		1,4	1,7		V
		$T_j = 125 \text{ }^\circ\text{C}_{\text{chiplev.}}$		1,4	1,7		V
V_{F0}		$T_j = 125 \text{ }^\circ\text{C}$		0,9	1		V
r_F		$T_j = 125 \text{ }^\circ\text{C}$		33	47		mΩ
I_{RRM}	$I_F = 30 \text{ A}$	$T_j = 125 \text{ }^\circ\text{C}$					A
Q_{rr}	$di/dt = 500 \text{ A}/\mu\text{s}$						μC
E_{rr}	$V_{CC}=300\text{V}$						mJ
$R_{th(j-s)D}$	per diode				2,3		K/W
Freewheeling diode							
$V_F = V_{EC}$	$I_{Fnom} = 60 \text{ A}; V_{GE} = 0 \text{ V}$	$T_j = 25 \text{ }^\circ\text{C}_{\text{chiplev.}}$		1,1	1,6		V
		$T_j = 150 \text{ }^\circ\text{C}_{\text{chiplev.}}$			1,25		V
V_{F0}		$T_j = 150 \text{ }^\circ\text{C}$		0,85			V
r_F		$T_j = 150 \text{ }^\circ\text{C}$		7			V
I_{RRM}	$I_F = 50 \text{ A}$	$T_j = 125 \text{ }^\circ\text{C}$		38			A
Q_{rr}	$di/dt = -1000 \text{ A}/\mu\text{s}$			2			μC
E_{rr}	$V_R=300\text{V}$			0,45			mJ
$R_{th(j-s)D}$	per diode				1,1		K/W
M_s	to heat sink			1,8	2		Nm
w				19			g

This is an electrostatic discharge sensitive device (ESDS), international standard IEC 60747-1, Chapter IX.

* The specifications of our components may not be considered as an assurance of component characteristics. Components have to be tested for the respective application. Adjustments may be necessary. The use of SEMIKRON products in life support appliances and systems is subject to prior specification and written approval by SEMIKRON. We therefore strongly recommend prior consultation of our personal.

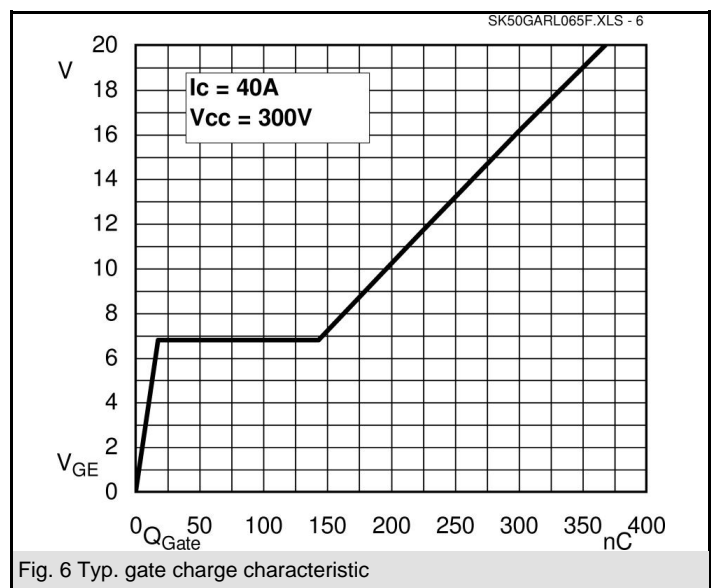
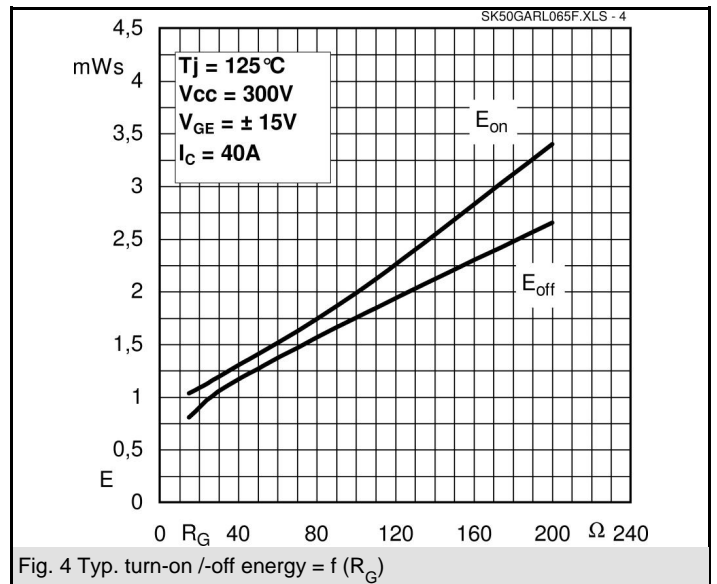
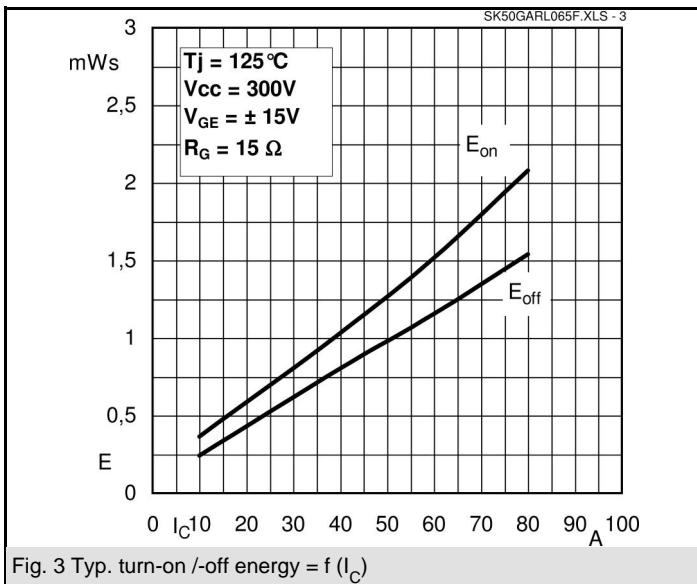
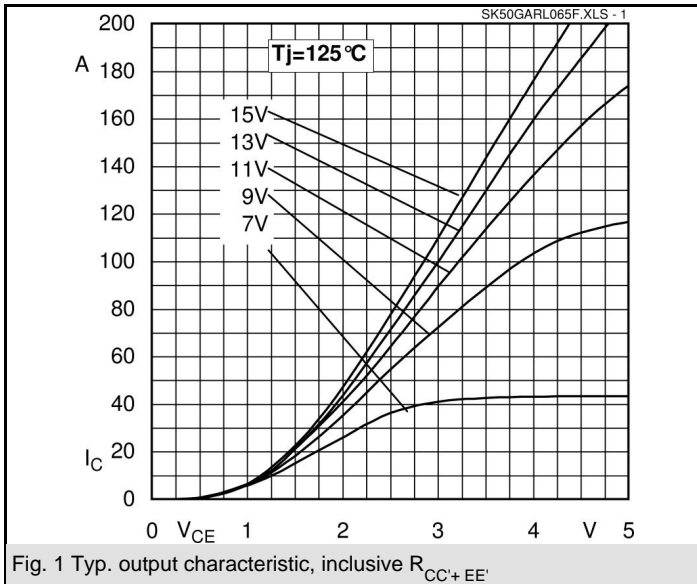

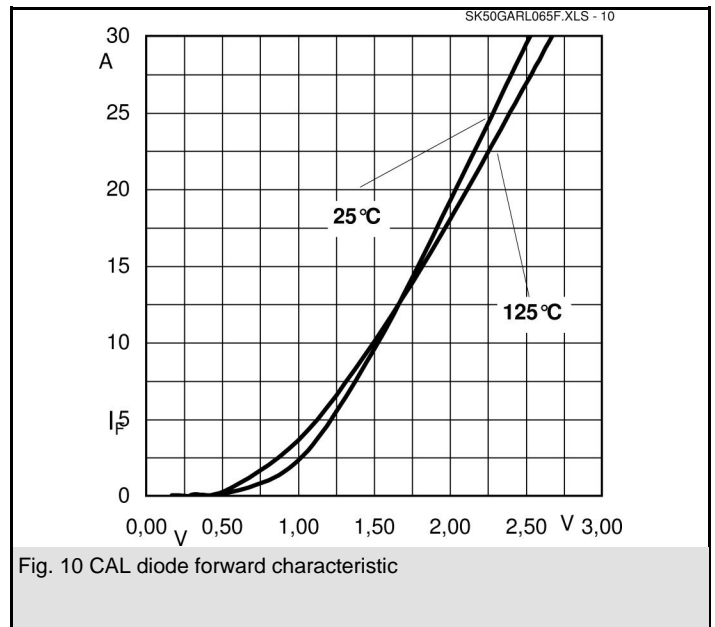
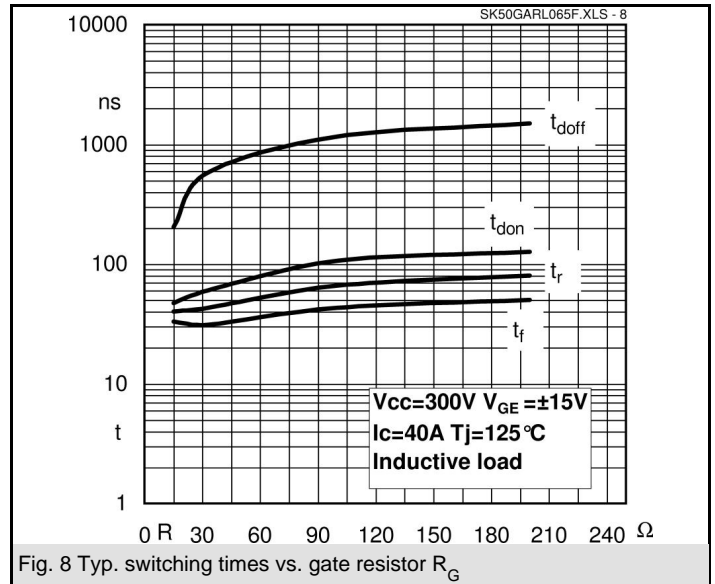
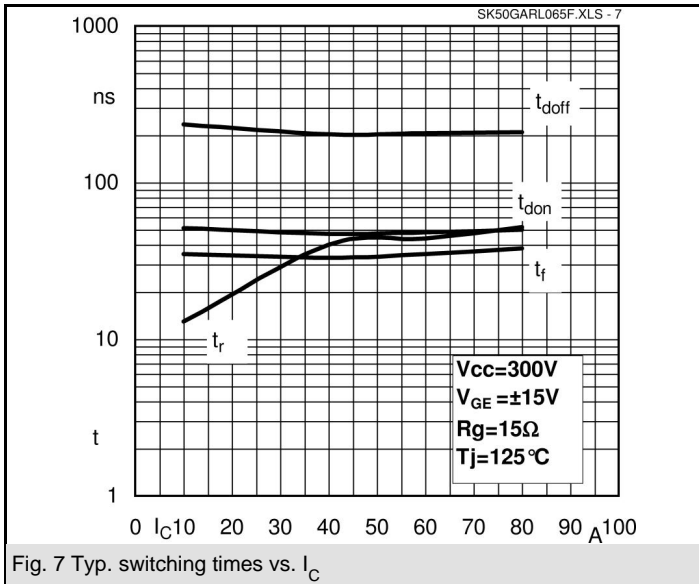

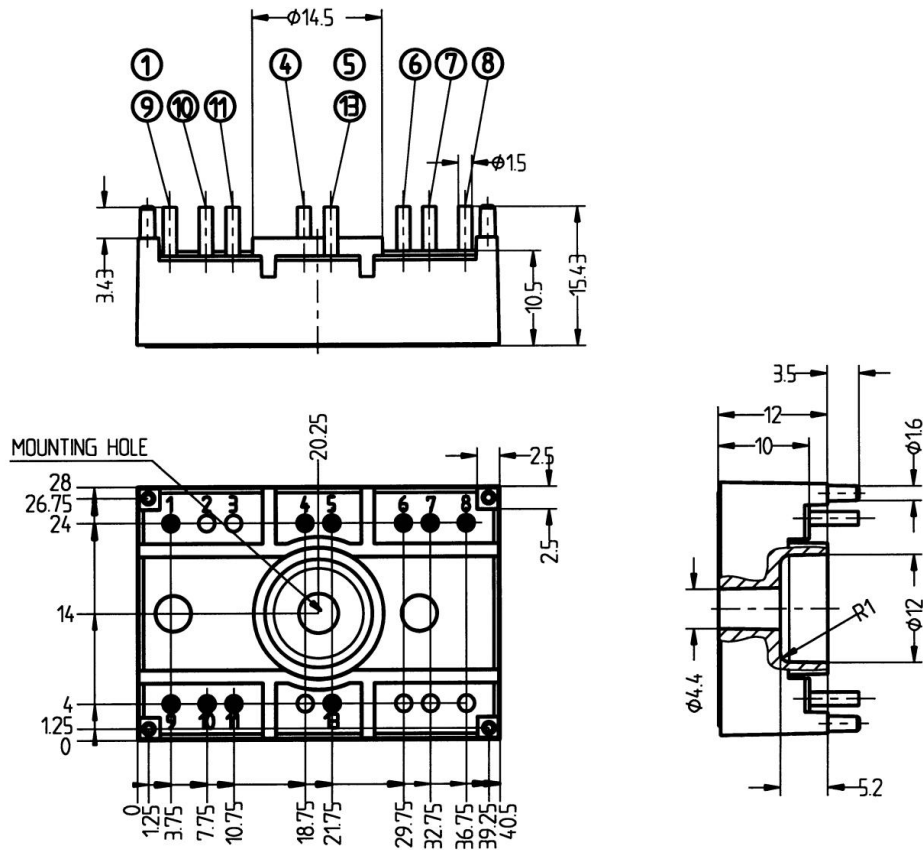

Case T31 (Suggested hole diameter, in the PCB, for solder pins and plastic mounting pins: 2mm)

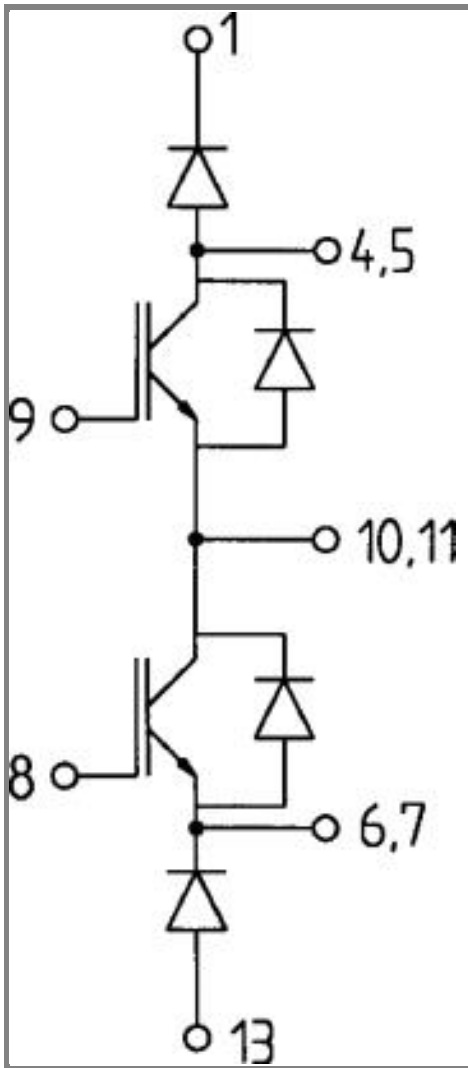

Case T31

GARL