

FUJI Power Semiconductors

IGBT Modules

IGBT 6-pack

Page 1



IGBT PIM

Page 3



IGBT Standard 2-pack/1-pack

Page 6



IGBT High Power Modules

Page 10



IGBT IPM

Page 12



IGBT Discretes

Page 13



IGBT 6-pack

	mm	Ic	600V		1200V		1700V
			Gen. 5 Planar-NPT	Gen. 6 Trench-FS	Gen. 5 Trench-FS	Gen. 6 Trench-FS	Gen. 5 Trench-FS
<p>M636 Solder pins</p>		35A			6MBI35U4A-120-50		
		50A		6MBI50VA-060-50	6MBI50U4A-120-50	6MBI50VA-120-50	
		75A	6MBI75U2A-060-50	6MBI75VA-060-50	6MBI75U4A-120-50	6MBI75VA-120-50	
		100A		6MBI100VA-060-50		6MBI100VA-120-50	
<p>M633 Solder pins</p>		75A					
		100A	6MBI100U2B-060-50		6MBI100U4B-120-50	6MBI100VB-120-50	6MBI100U4B-170-50
		150A	6MBI150U2B-060-50	6MBI150VB-060-50	6MBI150U4B-120-50	6MBI150VB-120-50	6MBI150U4B-170-50
		180A				6MBI180VB-120-50	
		180A				6MBI180VB-120-55	
<p>M647 Press fit pins</p>		50A		6MBI50VW-060-50		6MBI50VW-120-50	
		75A		6MBI75VW-060-50		6MBI75VW-120-50	
		100A		6MBI100VW-060-50		6MBI100VW-120-50	
<p>M648 Press fit pins</p>		100A				6MBI100VX-120-50	
		150A		6MBI150VX-060-50		6MBI150VX-120-50	
		180A				6MBI180VX-120-50	
		180A				6MBI180VX-120-55	

Note: Suffix '-50' in production number indicates RoHS compliant.
 6MBI180VB-120-55, 6MBI180VX-120-55; Premium type (Low Thermal Impedance Version)

IGBT 6-pack

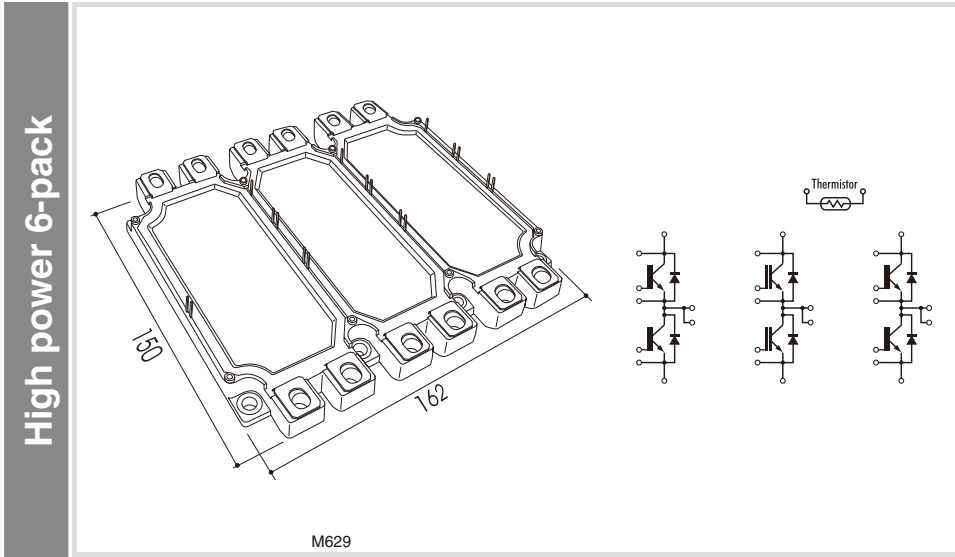

mm

Ic

	1200V		1700V	
	Gen. 5 Trench-FS	Gen. 6 Trench-FS	Gen. 5 Trench-FS	Gen. 6 Trench-FS
225A	6MBI225U4-120-50	6MBI225V-120-50	6MBI225U4-170	
300A	6MBI300U4-120-50	6MBI300V-120-50	6MBI300U4-170	6MBI300V-170-50
450A	6MBI450U4-120-50	6MBI450V-120-50	6MBI450U4-170	6MBI450V-170-50
550A		6MBI550V-120-50		

Note: Suffix '-50' in production number indicates RoHS compliant.

IGBT PIM (Power Integrated Module) mm

PIM

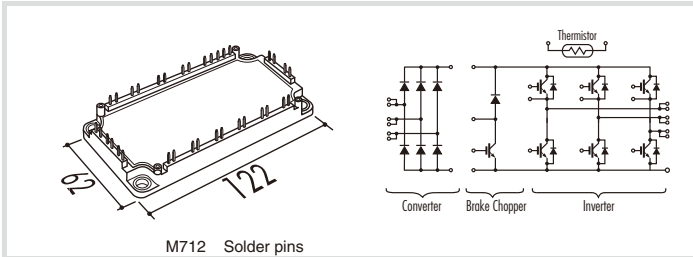
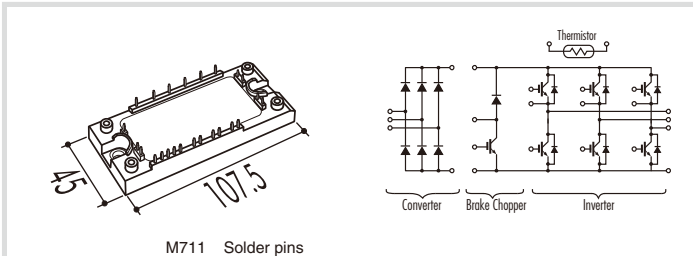

Ic	600V		1200V	
	Gen. 5 Trench/ Planar-NPT	Gen.6 Trench-FS	Gen. 5 Trench-FS	Gen.6 Trench-FS
10A				
15A				
25A			7MBR25UA120-50	7MBR25VA120-50
30A	7MBR30U2A060-50			
35A			7MBR35UA120-50	7MBR35VA120-50
50A	7MBR50U2A060-50	7MBR50VA060-50	7MBR50UA120-50	
35A			7MBR35UB120-50	7MBR35VB120-50
50A			7MBR50UB120-50	7MBR50VB120-50
75A	7MBR75U2B060-50	7MBR75VB060-50	7MBR75U4B120-50	7MBR75VB120-50
100A	7MBR100U2B060-50	7MBR100VB060-50	7MBR100U4B120-50	

Note: Suffix '-50' in production number indicates RoHS compliant.

IGBT PIM (Power Integrated Module) mm

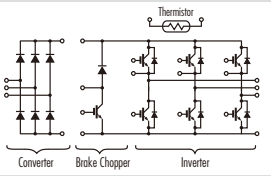
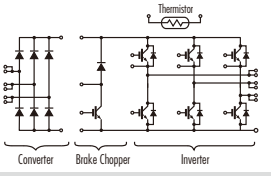
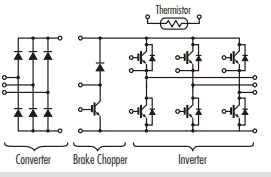
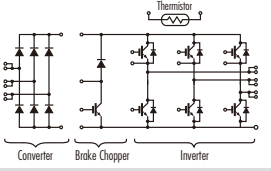
PIM	mm	Ic	600V	1200V	
			Gen. 6 Trench-FS	Gen. 6 Trench-FS	
M719 Solder pins	45	107.5		25A	7MBR25VM120-50 7MBR25VP120-50
				35A	7MBR35VM120-50 7MBR35VP120-50
				50A	7MBR50VP060-50
				75A	7MBR75VP060-50
M720 Solder pins	82	122		100A	7MBR100VP060-50
				50A	7MBR50VN120-50 7MBR50VR120-50
				75A	7MBR75VN120-50 7MBR75VR120-50
				100A	7MBR100VN120-50 7MBR100VR120-50
M721 Press fit pins	45	107.5		150A	7MBR150VR060-50
				25A	7MBR25VW120-50 7MBR25VY120-50
				35A	7MBR35VW120-50 7MBR35VY120-50
				50A	7MBR50VY060-50
M722 Press fit pins	82	122		75A	7MBR75VY060-50
				100A	7MBR100VY060-50
				50A	7MBR50VX120-50 7MBR50VZ120-50
				75A	7MBR75VX120-50 7MBR75VZ120-50
				100A	7MBR100VZ060-50
				150A	7MBR150VZ060-50

Note: Suffix '-50' in production number indicates RoHS compliant.

In/Out terminal Layout

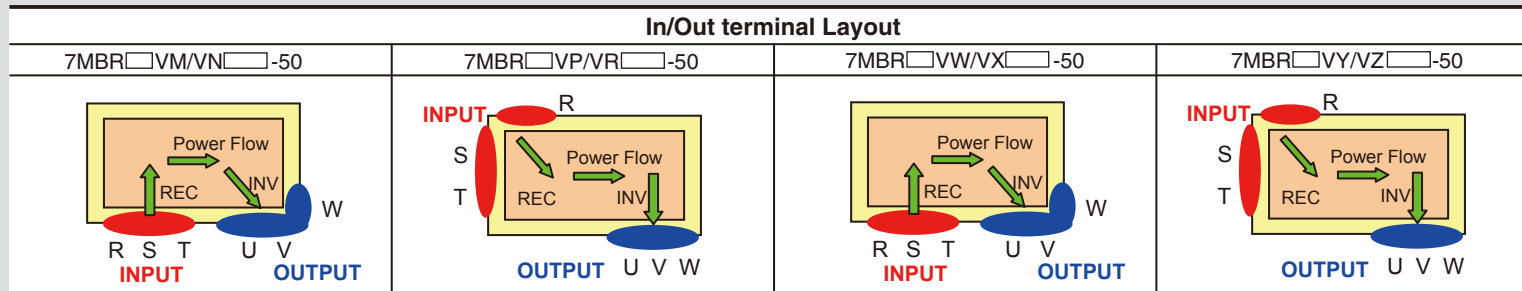

IGBT PIM (Power Integrated Module) mm

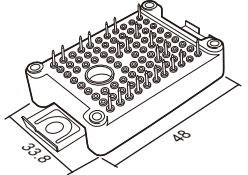
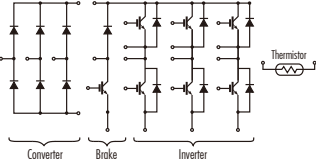
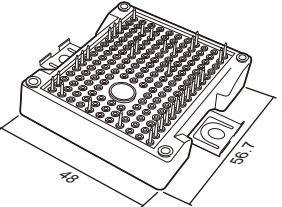
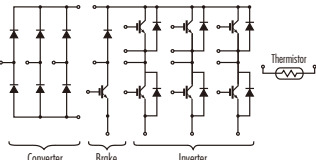
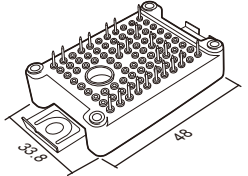
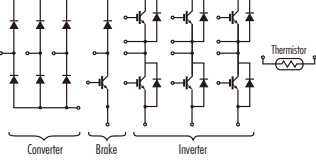
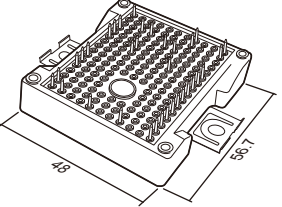
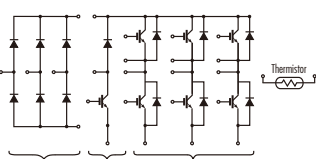
	mm	Ic	600V	1200V
			Gen. 6 Trench-FS	Gen. 6 Trench-FS
 <p>M726 Press fit pins</p>		10A	7MBR10VKA060-50 *	7MBR10VKA120-50
		15A	7MBR15VKA060-50 *	7MBR15VKA120-50
		20A	7MBR20VKA060-50 *	
		30A	7MBR30VKA060-50 *	
 <p>M727 Press fit pins</p>		15A		7MBR15VKB120-50
		25A		7MBR25VKB120-50
		35A		7MBR35VKB120-50
		50A	7MBR50VKB060-50 *	
 <p>M728 Solder pins</p>		10A	7MBR10VKC060-50 *	7MBR10VKC120-50
		15A	7MBR15VKC060-50 *	7MBR15VKC120-50
		20A	7MBR20VKC060-50 *	
		30A	7MBR30VKC060-50 *	
 <p>M729 Solder pins</p>		15A		7MBR15VKD120-50
		25A		7MBR25VKD120-50
		35A		7MBR35VKD120-50
		50A	7MBR50VKD060-50 *	

Note: Suffix '-50' in production number indicates RoHS compliant.

* Under development

IGBT Standard 2-pack mm

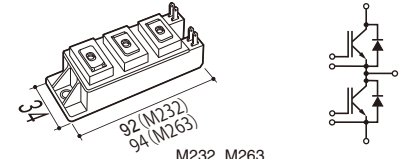
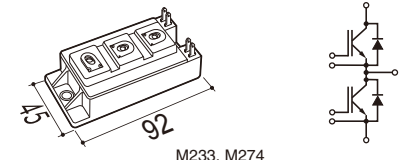
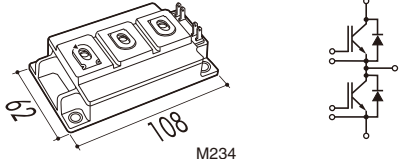
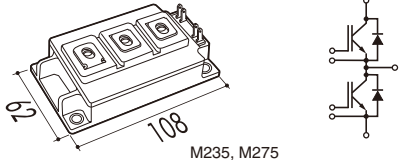
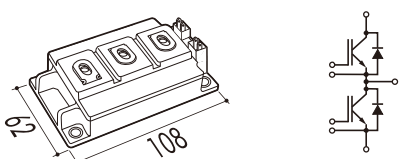
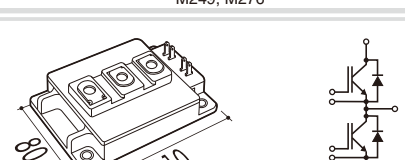
	Ic	600V		1200V		1700V	
		Gen. 5 Planar-NPT	Gen. 6 Trench-FS	Gen. 5 Trench-FS	Gen. 6 Trench-FS	Gen. 5 Trench-FS	Gen. 6 Trench-FS
 <p>M232, M263</p>	75A			2MBI75U4A-120-50	2MBI75VA-120-50		2MBI75VA-170-50
	100A		2MBI100VA-060-50	2MBI100U4A-120-50	2MBI100VA-120-50		2MBI100VA-170-50
	150A	2MBI150U2A-060-50	2MBI150VA-060-50	2MBI150U4A-120-50	2MBI150VA-120-50		
	200A	2MBI200U2A-060-50	2MBI200VA-060-50				
 <p>M233, M274</p>	100A						
	150A						
	200A			2MBI200U4B-120-50	2MBI200VB-120-50		
	300A	2MBI300U2B-060-50	2MBI300VB-060-50				
	400A	2MBI400U2B-060-50	2MBI400VB-060-50				
 <p>M234</p>	100A						
	150A						
	200A			2MBI200UC-120-50			
	300A			2MBI300UC-120-50			
 <p>M235, M275</p>	200A			2MBI200U4D-120-50			
	300A			2MBI300U4D-120-50	2MBI300VD-120-50		
	400A		2MBI400VD-060-50		2MBI400VD-120-50		
	600A		2MBI600VD-060-50				
 <p>M249, M276</p>	100A					2MBI100U4H-170-50	
	150A			2MBI150U4H-120-50		2MBI150U4H-170-50	2MBI150VH-170-50
	200A			2MBI200U4H-120-50	2MBI200VH-120-50	2MBI200U4H-170-50	2MBI200VH-170-50
	300A			2MBI300U4H-120-50	2MBI300VH-120-50	2MBI300U4H-170-50	2MBI300VH-170-50
	400A			2MBI400U4H-120-50		2MBI400U4H-170-50	
	450A				2MBI450VH-120-50		
 <p>M247, M277</p>	300A			2MBI300U4E-120	2MBI300VE-120-50		
	450A			2MBI450U4E-120	2MBI450VE-120-50		
	600A	2MBI600U2E-060	2MBI600VE-060-50		2MBI600VE-120-50		

Note: Suffix '-50' in production number indicates RoHS compliant.

• M232, M233, M234, M235, M249, M247: Gen.5 M263, M274, M275, M276, M277: Gen.6

IGBT Standard 2-pack mm

2-pack

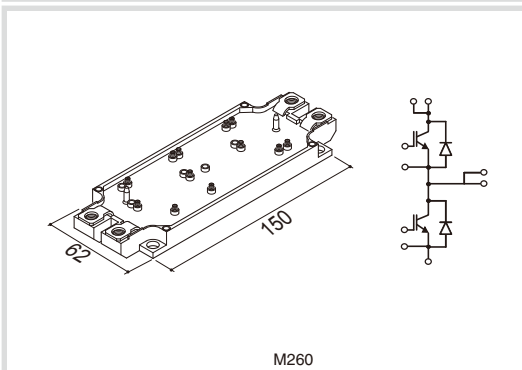
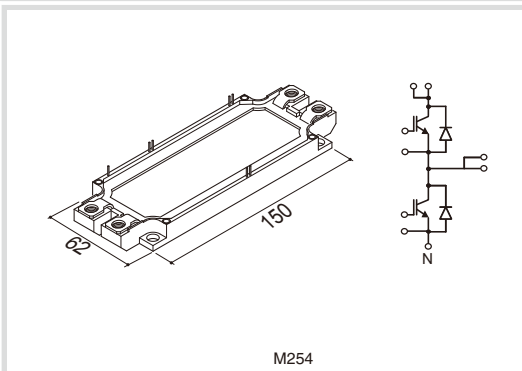

Ic	1200V		1700V	
	Gen. 5 Trench-FS	Gen. 6 Trench-FS	Gen. 5 Trench-FS	Gen. 6 Trench-FS
225A	2MBI225U4N-120-50	2MBI225VN-120-50	2MBI225U4N-170-50	
300A	2MBI300U4N-120-50	2MBI300VN-120-50	2MBI300U4N-170-50	2MBI300VN-170-50
450A	2MBI450U4N-120-50	2MBI450VN-120-50	2MBI450U4N-170-50	2MBI450VN-170-50
550A				2MBI550VN-170-50
600A		2MBI600VN-120-50		
225A	2MBI225U4J-120-50	2MBI225VJ-120-50		
300A	2MBI300U4J-120-50	2MBI300VJ-120-50		
450A	2MBI450U4J-120-50	2MBI450VJ-120-50		
550A				2MBI550VJ-170-50
600A		2MBI600VJ-120-50		

Note: Suffix '-50' in production number indicates RoHS compliant.

IGBT Standard 1-pack

mm

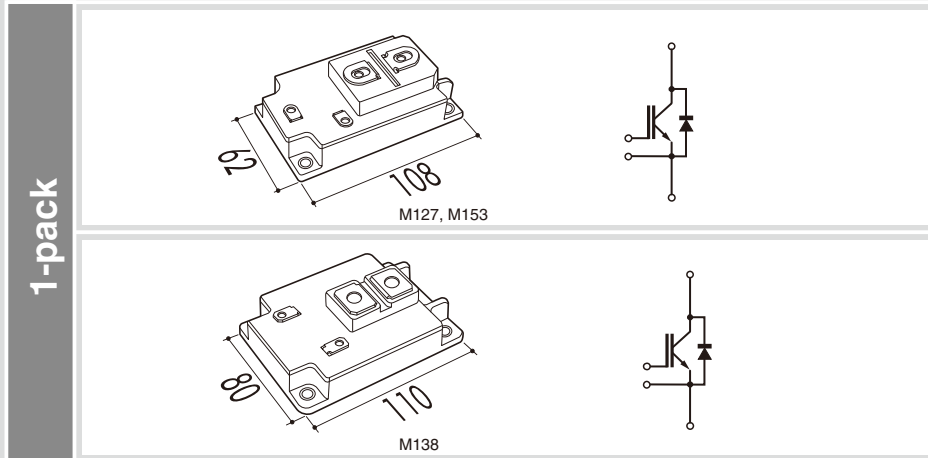

Ic

200A

300A

400A

600A

900A

600A

800A

1200V

**Gen. 5
Trench-FS**

**Gen. 6
Trench-FS**

1MBI300U4-120

1MBI400U4-120

1MBI600U4-120

1MBI400V-120-50

1MBI600V-120-50

1MBI900V-120-50

1MBI600U4B-120

1MBI800U4B-120

1MBI900V-120-50

Note: Suffix '-50' in production number indicates RoHS compliant. • M127: Gen.5 M153: Gen.6

IGBT Chopper

mm

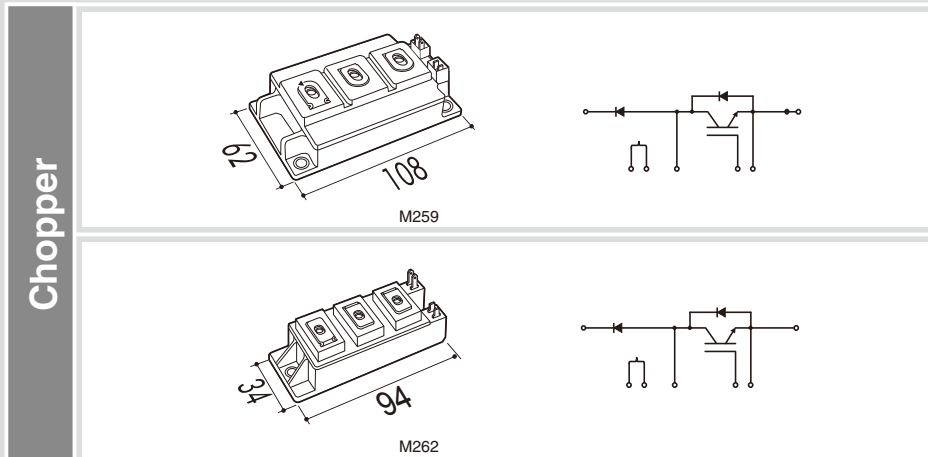

Ic

200A

300A

50A

75A

100A

600V

**Gen. 5
Planar-NPT**

1200V

**Gen. 5
Trench-FS**

1MBI300U2H-060L-50

1MBI200U4H-120L-50

1MBI50U4F-120L-50

1MBI75U4F-120L-50

1MBI100U4F-120L-50

Note: Suffix '-50' in production number indicates RoHS compliant.

IGBT High Speed Modules

mm

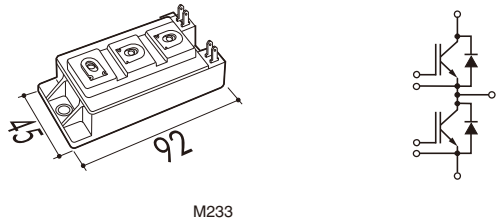
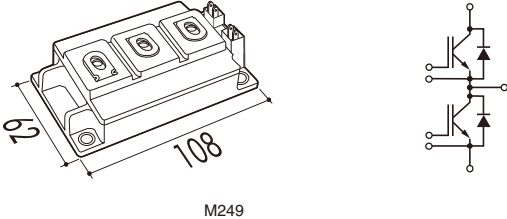
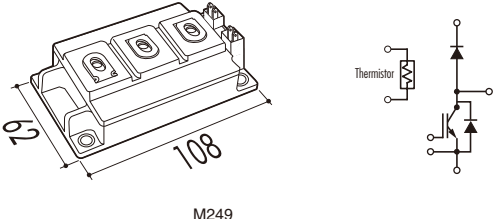
		1200V	
		High Speed IGBT	
2 pack	 <p>M233</p>	100A	2MBI100HB-120-50
	 <p>M249</p>	150A 200A	2MBI150HH-120-50 2MBI200HH-120-50
	 <p>M249</p>	200A 300A 400A	1MBI200HH-120L-050 1MBI300HH-120L-050 1MBI400HH-120L-050

Note: Suffix '-50' in production number indicates RoHS compliant.

IGBT High Power Module mm

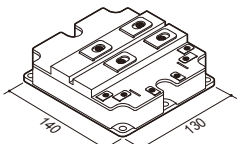
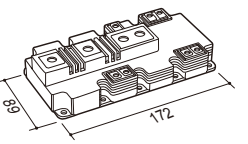
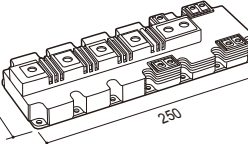
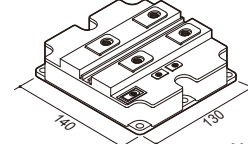
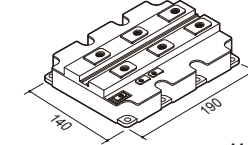
		1200V		1700V		
		Gen. 5	Gen. 6	Gen. 5	Gen. 6	
		Trench-FS	Trench-FS	Trench-FS	Trench-FS	
		Ic				
2-pack	 M256	600A	2MBI600U4G-120	2MBI600VG-120 *	2MBI600U4G-170	2MBI600VG-170E
		800A	2MBI800U4G-120	2MBI800VG-120 *	2MBI800U4G-170	2MBI800VG-170E
		1200A	2MBI1200U4G-120	2MBI1200VG-120 *	2MBI1200U4G-170	2MBI1200VG-170E
2-pack PrimePACK™	 M271	600A		2MBI600VXA-120E-50		
		650A				2MBI650VXA-170E-50
		900A		2MBI900VXA-120E-50 2MBI900VXA-120P-50		
	 M272	1000A				2MBI1000VXB-170E-50
		1400A		2MBI1400VXB-120P-50		2MBI1400VXB-170E-50 * 2MBI1400VXB-170P-50 *
1-pack	 M151	1200A	1MBI1200U4C-120	1MBI1200VC-120 *	1MBI1200U4C-170	1MBI1200VC-170E
		1600A	1MBI1600U4C-120	1MBI1600VC-120 *	1MBI1600U4C-170	1MBI1600VC-170E
		2400A		1MBI2400VC-120 *		1MBI2400VC-170E
	 M152	2400A	1MBI2400U4D-120	1MBI2400VD-120 *	1MBI2400U4D-170	1MBI2400VD-170E
		3600A	1MBI3600U4D-120	1MBI3600VD-120 *	1MBI3600U4D-170	1MBI3600VD-170E

Note: Suffix '-50' in production number indicates RoHS compliant.
PrimePACK™ is registered trademark of Infineon Technology AG, Germany.

* Under development

IGBT High Power Module

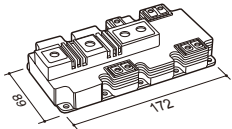
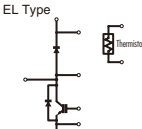
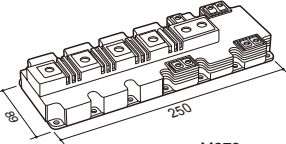
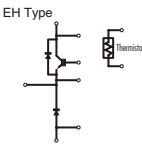
		mm	Ic	1700V
Chopper PrimePACK™		172	650A	Gen. 6 Trench-FS 1MBI650VXA-170EL-50 1MBI650VXA-170EH-50
	EL Type 			
		250	1000A	1MBI1000VXB-170EL-50 1MBI1000VXB-170EH-50
	EH Type 			

Note: Suffix '-50' in production number indicates RoHS compliant.
 PrimePACK™ is registered trademark of Infineon Technology AG, Germany.

IGBT Advanced NPC 3-level Circuits

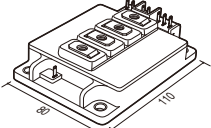
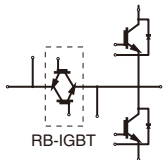
		mm	Ic	600V	1200V
3-level		110	300A	Gen. 6 Trench-FS 4MBI400VG-060R-50	Gen. 6 Trench-FS 4MBI300VG-120R-50
		RB-IGBT 	400A		

Note: Suffix '-50' in production number indicates RoHS compliant.

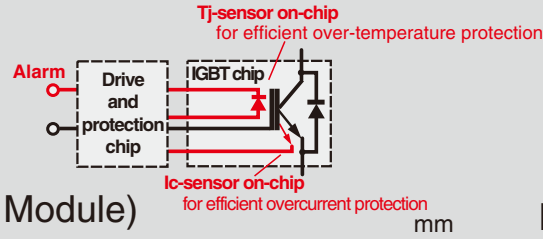

IGBT IPM (Intelligent Power Module)

		600V	1200V		
		Gen. 6 Trench-FS	Gen. 6 Trench-FS		
Without brake-chopper	P629 	10A	6MBP10VAA120-50		
		15A	6MBP15VAA120-50		
	P626 	20A	6MBP20VAA060-50		
		25A	6MBP25VAA120-50		
		30A	6MBP30VAA060-50		
		50A	6MBP50VAA060-50		
Without brake-chopper	P630 	25A	6MBP25VBA120-50		
		35A	6MBP35VBA120-50		
	P631 	50A	6MBP50VBA060-50		
		75A	6MBP75VBA060-50		
		With brake-chopper	P630 	25A	6MBP25VDA120-50
				35A	6MBP35VDA120-50
P631 	50A		6MBP50VDA060-50		
	75A		6MBP75VDA060-50		
	100A		6MBP100VDA120-50		
	150A		6MBP150VDA060-50		
Without brake-chopper	P630 	25A	7MBP25VDA120-50		
		35A	7MBP35VDA120-50		
	P631 	50A	7MBP50VDA060-50		
		75A	7MBP75VDA060-50		
		100A	7MBP100VDA120-50		
		150A	7MBP150VDA060-50		
With brake-chopper	P631 	200A	7MBP200VDA060-50		
		100A	6MBP100VEA120-50		
	P631 	150A	6MBP150VEA120-50		
		200A	6MBP200VEA060-50		
		300A	6MBP300VEA060-50		
		400A	6MBP400VEA060-50		
With brake-chopper	P631 	100A	7MBP100VEA120-50		
		150A	7MBP150VEA120-50		
	P631 	200A	7MBP200VEA060-50		
		300A	7MBP300VEA060-50		
		400A	7MBP400VEA060-50		
		400A	7MBP400VEA060-50		

Note: Suffix '-50' in production number indicates RoHS compliant.

IGBT Discretes

mm

Ic

TO-247 -P2

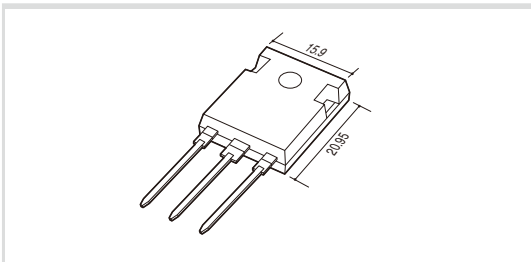

		600V			1200V		
		Trench-FS V series	Trench-FS High Speed V series		Trench-FS V series	Trench-FS High Speed V series	
15A					FGW15N120VD	FGW15N120HD	FGW15N120H
25A					FGW25N120VD		
30A	FGW30N60VD					FGW30N120HD	FGW30N120H
35A			FGW35N60HD	FGW35N60H			
40A					FGW40N120VD	FGW40N120HD	FGW40N120H
50A	FGW50N60VD		FGW50N60HD	FGW50N60H			
75A	FGW75N60VD *		FGW75N60HD	FGW75N60H			

* Under development

Package Outlines, mm

M127

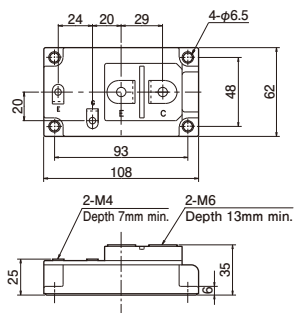

M138

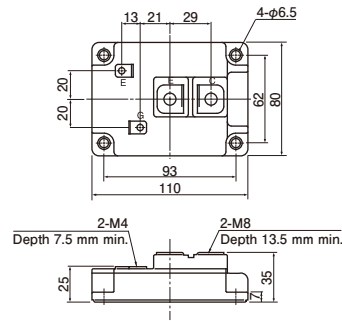

M233

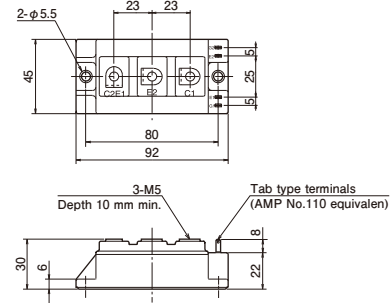

M234

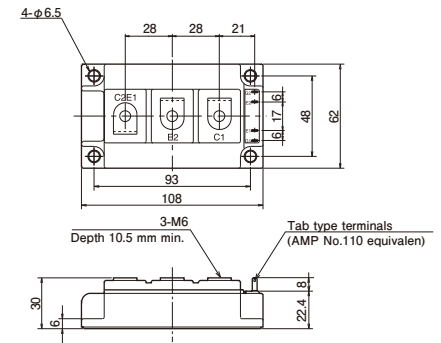

M151

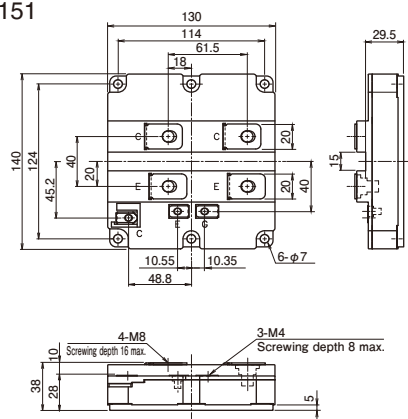

M152

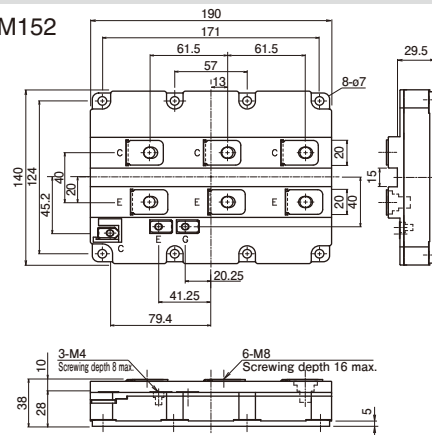

M235

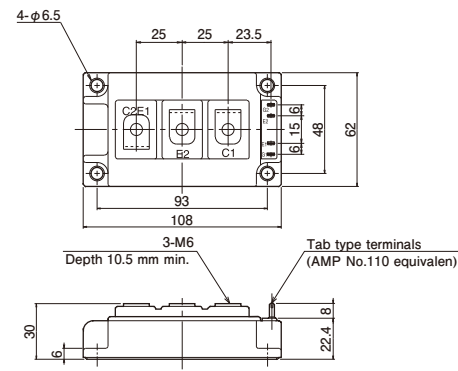

M247

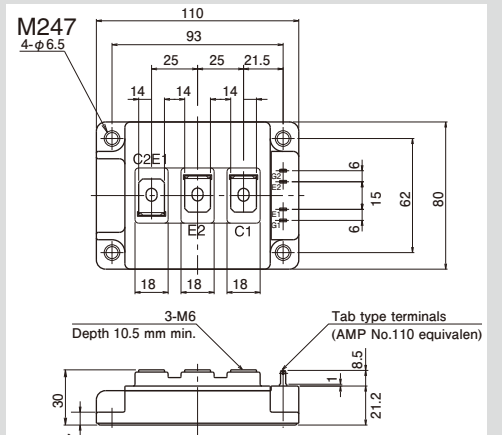

M153

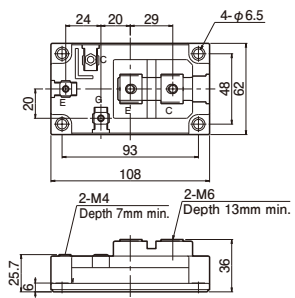

M232

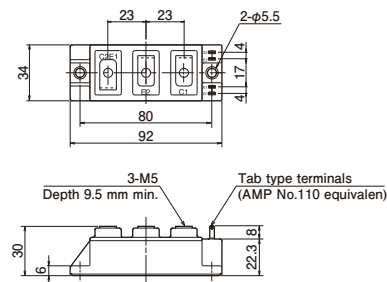

M249

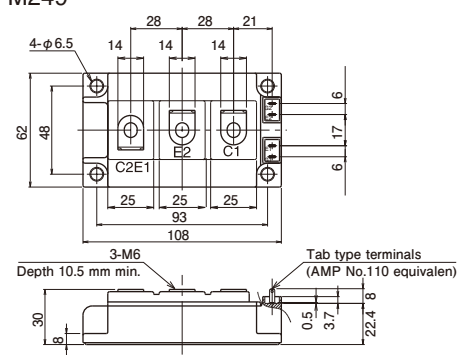

M250

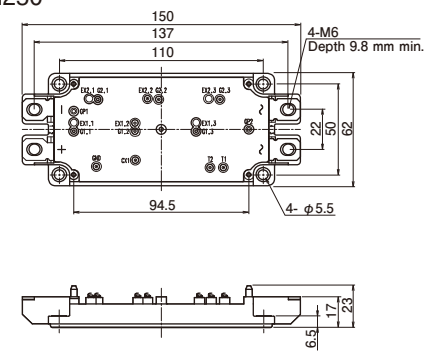

Package Outlines, mm

M254

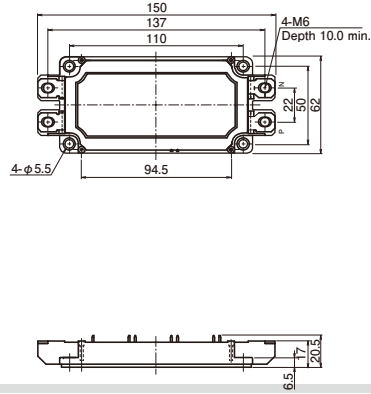

M256

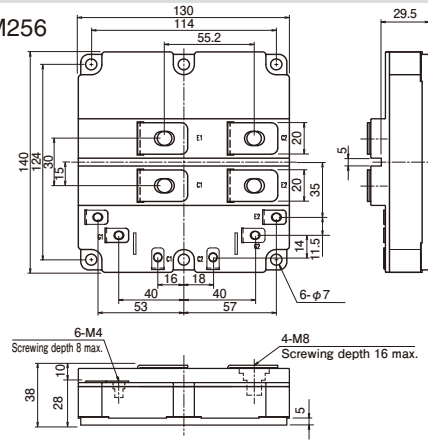

M271

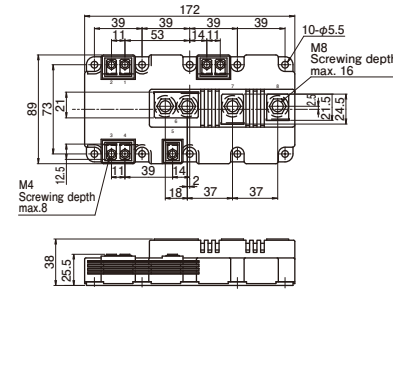

M272

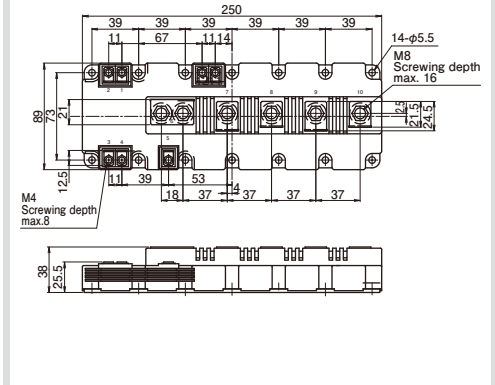

M259

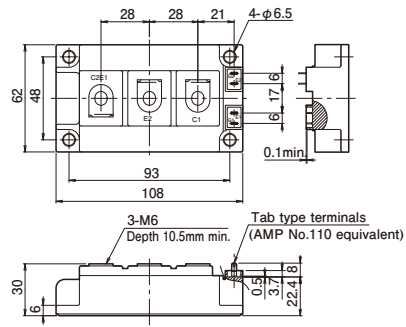

M260

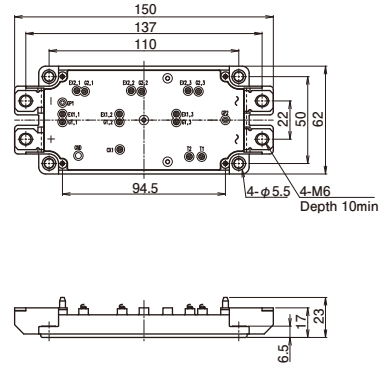

M274

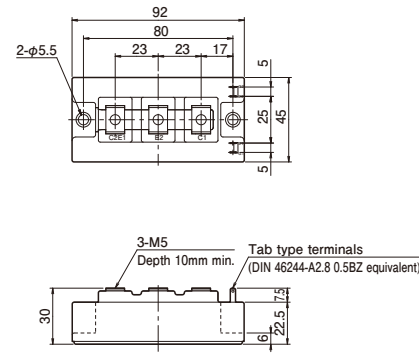

M275

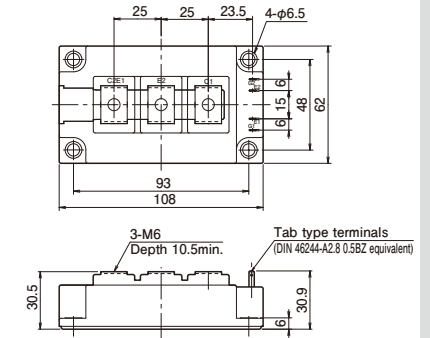

M262

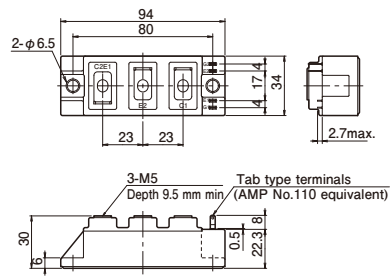

M263

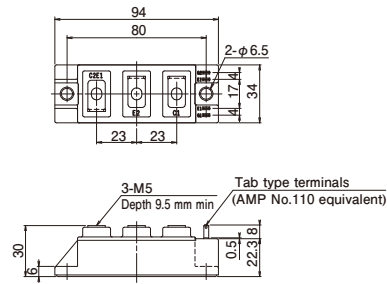

M276

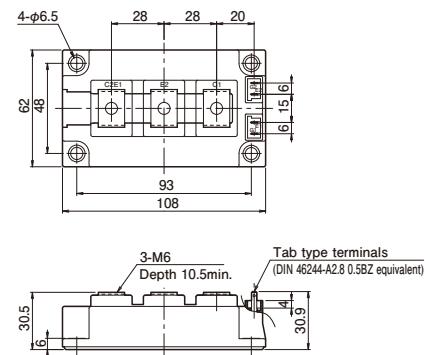

M277

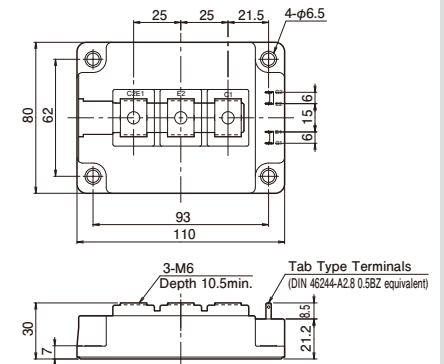

Package Outlines, mm

M403

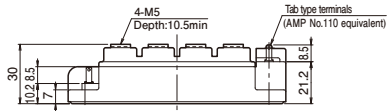
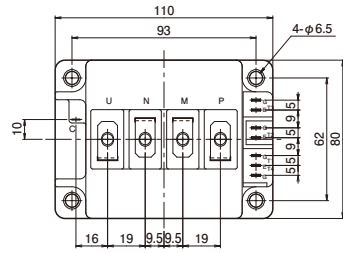

M629

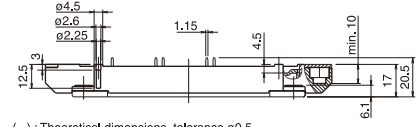
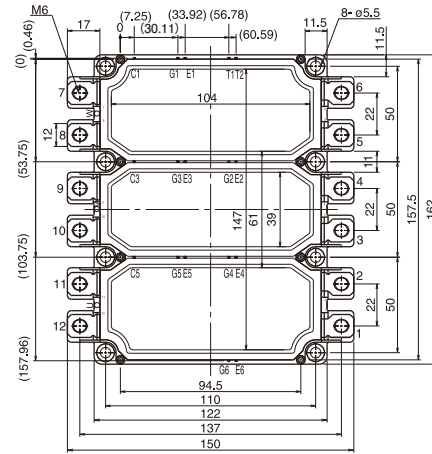

() : Theoretical dimensions, tolerance ± 0.5

M647

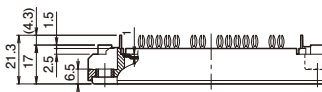
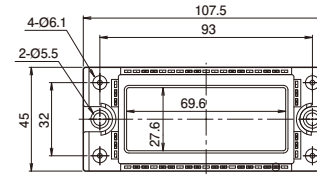

Press fit pins

M648

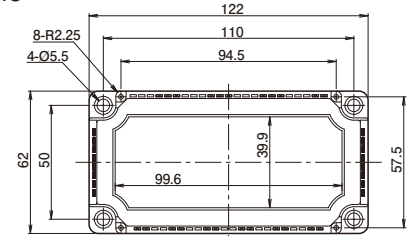

Press fit pins

M711

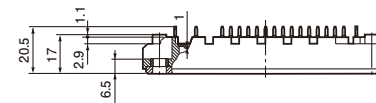
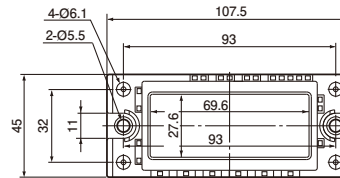

Solder pins

M712

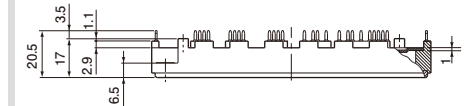
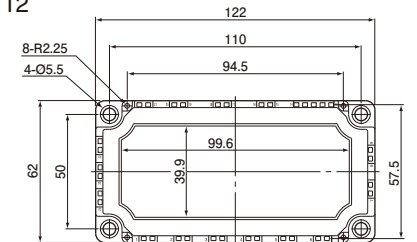

Solder pins

M633

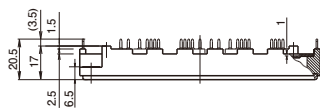
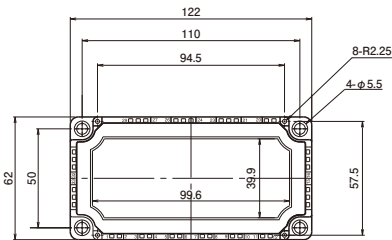

Solder pins

M636

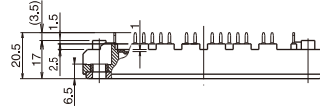
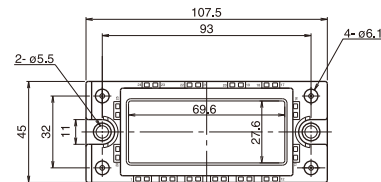

Solder pins

M719

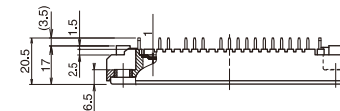
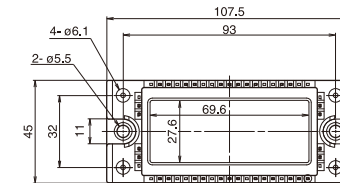

Solder pins

M720

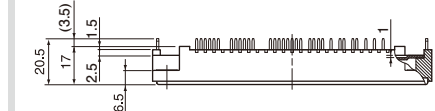
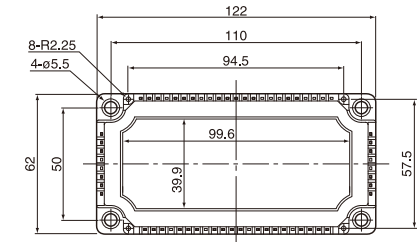

Solder pins

Package Outlines, mm

M721

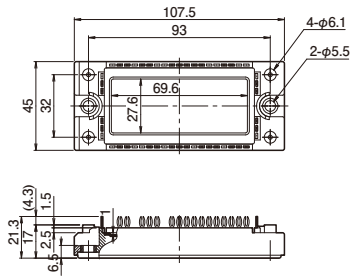

Press fit pins

M722

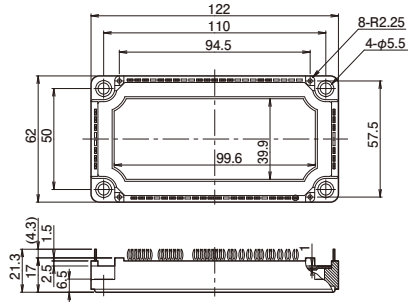

Press fit pins

P626

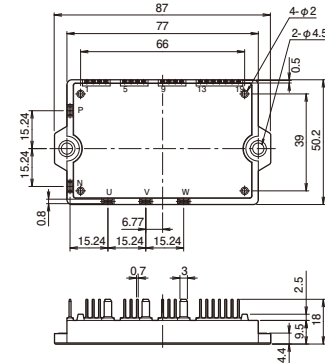

P629

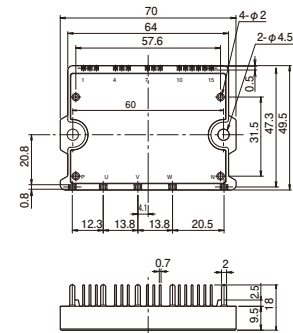

M726

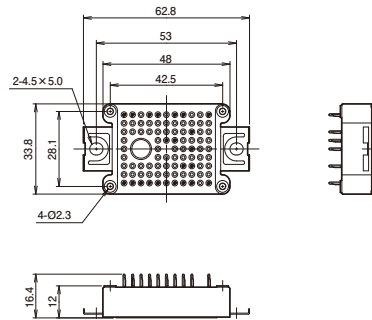

Press fit pins

M727

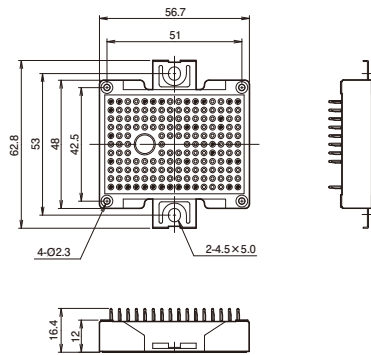

Press fit pins

P630

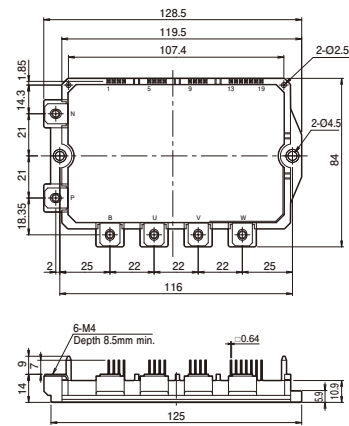

P631

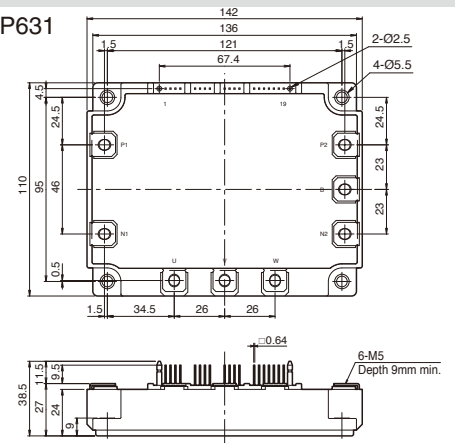

M728

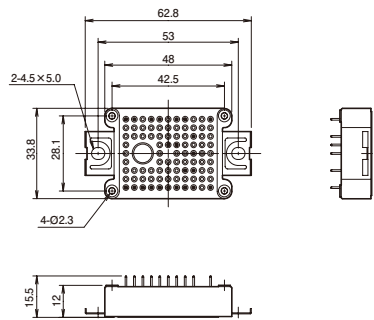

Solder pins

M729

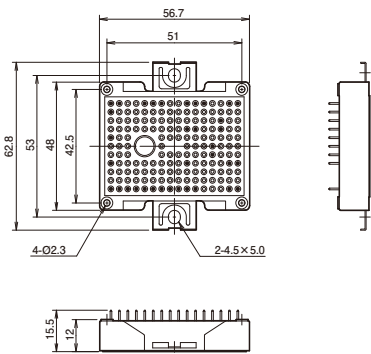

Solder pins

Package Outlines, mm

TO-247-P2

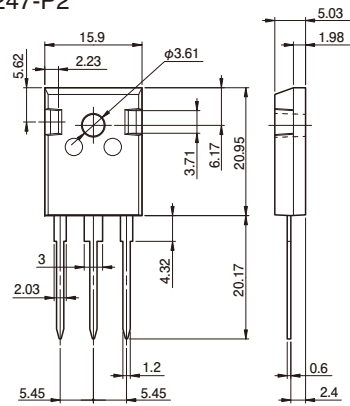

Fuji Electric Co., Ltd.
Power Semiconductors Group

<http://www.fujielectric.com/products/semiconductor/>

Fuji Electric Hong Kong Co., Limited

Unit 227-230, 2nd Floor, No.1 Science Park West Avenue,
Hong Kong Science Park, Shatin, N.T., Hong Kong.
Tel: +852-2664-8699

Fuji Electric Taiwan Co., Ltd.

9F-1, No. 111, Sung Chiang Road, Taipei, TAIWAN
Tel: +886-2-2515-1850

Fuji Electric Asia Pacific Private Ltd.

171 Chin Swee Road, #12-01, San Centre, SINGAPORE 169877
Tel: +65-6533-0014

Fuji Electric (China) Co., Ltd

F27, International Corporate City,
No.3000 Zhongshan North Road,
Shanghai 200063 P.R.C., CHINA
Tel: +86-21-5496-1177

Fuji Electric Corp. of America

50 Northfield Avenue
Edison, NJ 08837, USA
Tel: +1-732-560-9410

Fuji Electric Europe GmbH

Goethering 58, 63067 Offenbach, am Main, F.R. GERMANY
Tel: +49-69-6690290