

SIRIUS SAFETY RELAY OUTPUT EXTENSION 4RO WITH RELAY ENABLING CIRCUITS 4 NO CONTACTS + RELAY FEEDBACK CIRCUIT 1 NC CONTACT US = 24 V DC SPRING-LOADED CONNECTION



Figure similar

General technical data:	
product brand name	SIRIUS
Product designation	safety relays
Design of the product	Expansion unit
Protection class IP of the enclosure	IP20
Protection against electrical shock	finger-safe
Insulation voltage Rated value	300 V
Ambient temperature	
• during storage	-40 ... +80 °C
• during operation	-25 ... +60 °C
Air pressure acc. to SN 31205	90 ... 106 kPa
Relative humidity during operation	10 ... 95 %
Installation altitude at height above sea level maximum	2 000 m
Vibration resistance acc. to IEC 60068-2-6	5 ... 500 Hz: 0,75 mm
Shock resistance	10g / 11 ms
Surge voltage resistance Rated value	4 000 V
EMC emitted interference	IEC 60947-5-1, IEC 61000

Installation environment regarding EMC	This product is suitable for Class B environments and can also be used in domestic environments.
Overvoltage category	Installation category III
Degree of pollution	3
Equipment marking acc. to DIN EN 61346-2	F
Safety Integrity Level (SIL) acc. to IEC 61508	SIL3
Performance level (PL) acc. to EN ISO 13849-1	e
Category acc. to EN ISO 13849-1	4
PFHD with high demand rate acc. to EN 62061	0.0000000017 1/h
Average probability of failure on demand (PFDavg) with low demand rate acc. to IEC 61508	0.000001 1/y
T1 value for proof test interval or service life acc. to IEC 61508	20 y
Hardware fault tolerance acc. to IEC 61508	1
Safety device type acc. to IEC 61508-2	Type A
Number of outputs as contact-affected switching element	
• as NC contact	
— for signaling function instantaneous contact	0
— for signaling function delayed switching	0
— safety-related instantaneous contact	0
— safety-related delayed switching	0
• as NO contact	
— for signaling function instantaneous contact	0
— for signaling function delayed switching	0
— safety-related instantaneous contact	4
— safety-related delayed switching	0
Stop category acc. to DIN EN 60204-1	0

General technical data:

Type of electrical connection Plug-in socket	No
Operating frequency maximum	360 1/h
Switching capacity current of the NO contacts of the relay outputs	
• at DC-13	
— at 24 V	5 A
— at 115 V	0.2 A
— at 230 V	0.1 A
• at AC-15	
— at 24 V	5 A
— at 115 V	5 A
— at 230 V	5 A

Thermal current of the switching element with contacts maximum	5 A
Operating current at 17 V minimum	5 mA
Mechanical service life (switching cycles) typical	10 000 000
Design of the fuse link for short-circuit protection of the NO contacts of the relay outputs required	gL/gG: 6A or circuit breaker type A: 3A or circuit breaker type B: 2A or circuit breaker type C: 1A
Make time with automatic start	
• typical	15 ms
• at DC maximum	30 ms
Make time with automatic start after power failure	
• typical	15 ms
• maximum	30 ms
Backslide delay time in the event of power failure	
• typical	10 ms
• maximum	15 ms
Recovery time after power failure typical	0.015 s

Control circuit/ Control:

Type of voltage of the control supply voltage	DC
Control supply voltage	
• at DC	
— Rated value	24 V
Operating range factor control supply voltage rated value of the magnet coil	
• at DC	0.8 ... 1.2
Active power loss typical	2.5 W

Installation/ mounting/ dimensions:

mounting position	any
Required spacing for grounded parts at the side	5 mm
Required spacing with side-by-side mounting at the side	0 mm
Mounting type	screw and snap-on mounting
Width	22.5 mm
Height	100 mm
Depth	121.6 mm

Connections/ Terminals:

Type of electrical connection	spring-loaded terminals
Type of connectable conductor cross-section	
• solid	1x (0.5 ... 1.5 mm ²), 2x (0.5 ... 1.5 mm ²)
• finely stranded	
— with core end processing	1x (0.5 ... 1.0 mm ²), 2x (0.5 ... 1.0 mm ²)
— without core end processing	1x (0.5 ... 1.5 mm ²), 2x (0.5 ... 1.5 mm ²)

Type of connectable conductor cross-section for AWG conductors	
<ul style="list-style-type: none"> • solid 	1x (20 ... 16), 2x (20 ... 16)
<ul style="list-style-type: none"> • stranded 	1x (20 ... 16), 2x (20 ... 16)

Product Function:	
Product function parameterizable	undelayed/delayed (only with system connector)
Suitability for operation Device connector 3ZY12	Yes
Suitability for use	
<ul style="list-style-type: none"> • safety-related circuits 	Yes

Certificates/ approvals:	
Certificate of suitability	
<ul style="list-style-type: none"> • TÜV (German technical inspectorate) certificate 	Yes
<ul style="list-style-type: none"> • UL approval 	Yes

General Product Approval	EMC	Functional Safety/Safety of Machinery	Declaration of Conformity
---------------------------------	------------	--	----------------------------------



[Baumusterbescheinigung](#)



Test Certificates	other
--------------------------	--------------

[Typprüfbescheinigung/Werkszeugnis](#)

[Bestätigungen](#)

Further information

Information- and Downloadcenter (Catalogs, Brochures,...)

<http://www.siemens.com/industrial-controls/catalogs>

Industry Mall (Online ordering system)

<http://www.siemens.com/industrymall>

Cax online generator

<http://support.automation.siemens.com/WW/CAXorder/default.aspx?lang=en&mlfb=3SK12112BB40>

Service&Support (Manuals, Certificates, Characteristics, FAQs,...)

<https://support.industry.siemens.com/cs/ww/en/ps/3SK12112BB40>

Image database (product images, 2D dimension drawings, 3D models, device circuit diagrams, EPLAN macros, ...)

http://www.automation.siemens.com/bilddb/cax_de.aspx?mlfb=3SK12112BB40&lang=en

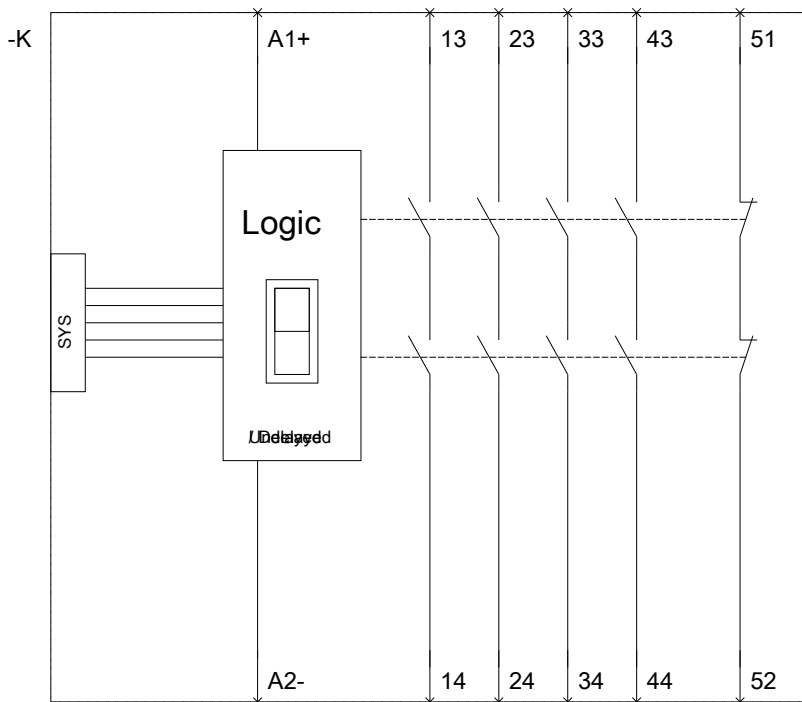
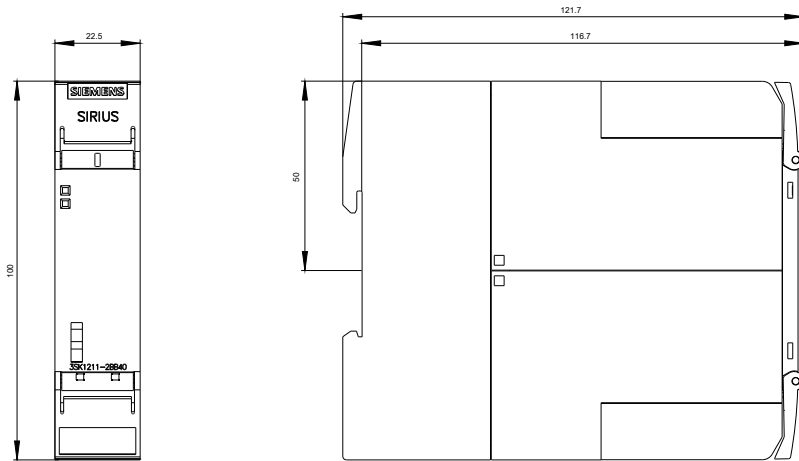

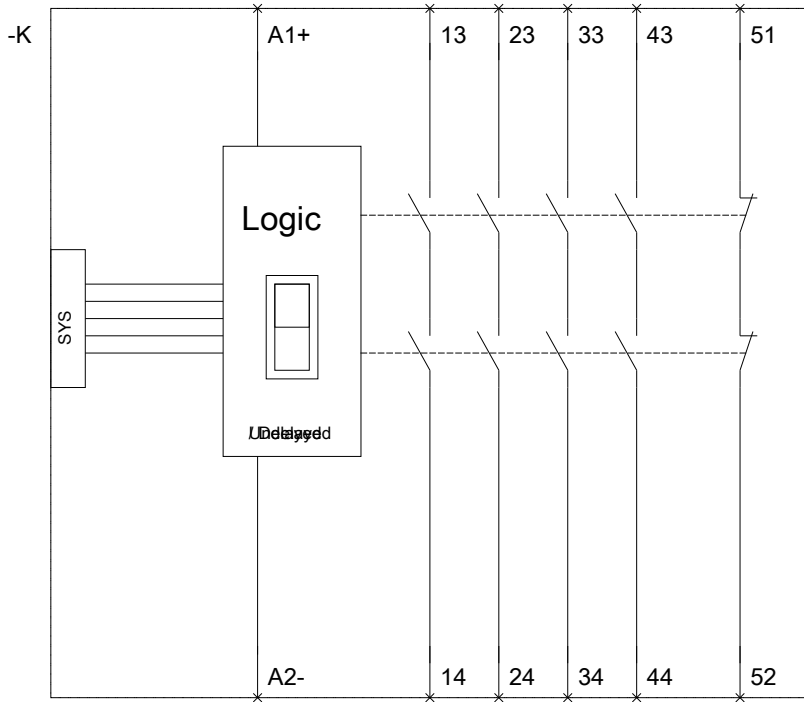

last modified:

20.07.2015